

HIGH TEMPERATURE INDUCTIVE PROXIMITY SENSORS

Sensing Distance: 2 mm - Housing Diameter: M8

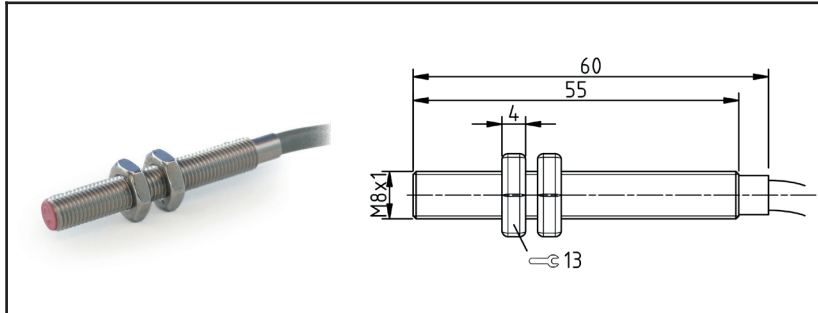

Dimensions are in mm.

Part Numbers:	
PNP/NO	IN2-8HTPS-140
PNP/NC	IN2-8HTPO-140
NPN/NO	IN2-8HTNS-140
NPN/NC	IN2-8HTNO-140

Technical Data:	
Mounting:	Shielded
Sensing range in mm:	2
Supply voltage:	10-35 VDC
Output function:	N.O. or N.C.
Load current:	120 mA up to 266 °F (130 °C), 70 mA up to 284 °F (140 °C)
Switching Frequency:	800 Hz
Short circuit limit:	400 mA
Cable version:	Silicone
Operating temperature:	-13 to 284 °F (-25 to 140 °C)
Target size:	8 x 8 x 1 mm ST37
Hysteresis:	3 to 15 %
LED:	No
Options:	Cable length, Cable type

This sensor has the following specifications:

<ul style="list-style-type: none"> * The EMC (Electromagnetic Compatibility) resistance of the switches: IEC 61000-4-2 Level 2 IEC 61000-4-4 Level 2 IEC 61000-4-3 Level 2 IEC 60255-5 1 kV * Sensing range can vary +/-20 %. * Voltage spikes (300 V for 1 ms, 10 Hz) * All standard cables are 3 x 0.25 mm² and a length of 2 m. * Output capacity is 100 nF. * Storage temperature -13 °F to + 176 °F (-25 °C to 80 °C). * Relative humidity is 100 %. 	<ul style="list-style-type: none"> * Vibration resistant to 1 mm amplitude at 55 Hz. * Shock resistant to 10 g for a period of 11 ms. * Degree of protection (DIN 40 050) is IP67 (higher IP options may be available). * Reverse polarity protection is incorporated on the supply voltage. * Load resistor of 100 kOhm is incorporated. * Leakage current is 4 mA at 24 V supply voltage. * Residual ripple is 15 %. * Voltage drop is approximately 2 V when sensor is on. * Sensing face material is: LPC-Vectra.
--	--

Wiring Diagram PNP NO/NC

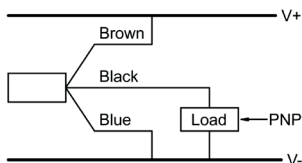

Special types and silicone free versions are available upon request

Wiring Diagram NPN NO/NC

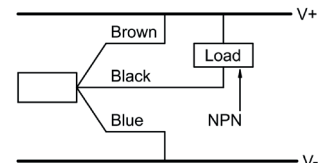

Design and technical details subject to change

Locon Sensor Systems, Inc.

HIGH TEMPERATURE INDUCTIVE PROXIMITY SENSORS

Sensing Distance: 3mm - Housing Diameter: M12

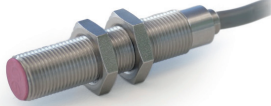
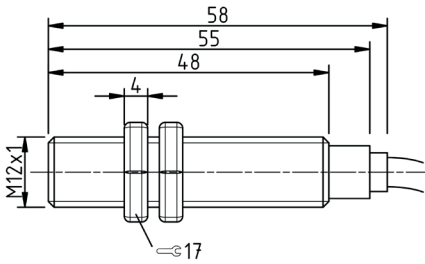

Dimensions are in mm.

Part Numbers:	
PNP/NO	IN3-12HTPS-150
PNP/NC	IN3-12HTPO-150
NPN/NO	IN3-12HTNS-150
NPN/NC	IN3-12HTNO-150

Technical Data:	
Mounting:	Shielded
Sensing range in mm:	3
Supply voltage:	10-35 VDC
Output function:	N.O. or N.C.
Load current:	120 mA up to 266 °F (130 °C), 70 mA up to 302 °F (150 °C)
Switching Frequency:	500 Hz
Short circuit limit:	400 mA
Cable version:	Silicone
Operating temperature:	-13 to 302 °F (-25 to 150 °C)
Target size:	12 x 12 x 1 mm ST37
Hysteresis:	3 to 15 %
LED:	No
Options:	Cable length, Cable type

Dimensions are in mm.

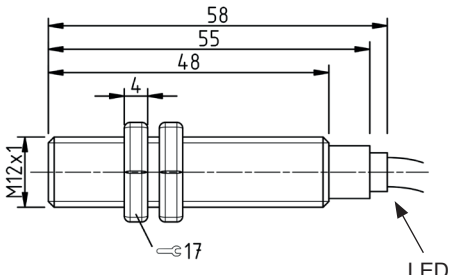
Part Numbers:	
PNP/NO	IN3-12HTPS/L-130
PNP/NC	IN3-12HTPO/L-130
NPN/NO	IN3-12HTNS/L-130
NPN/NC	IN3-12HTNO/L-130

Technical Data:		with LED
Mounting:	Shielded	
Sensing range in mm:	3	
Supply voltage:	10-35 VDC	
Output function:	N.O. or N.C.	
Load current:	120 mA	
Switching Frequency:	500 Hz	
Short circuit limit:	400 mA	
Cable version:	Silicone	
Operating temperature:	-13 to 266 °F (-25 to 130 °C)	
Target size:	12 x 12 x 1 mm ST37	
Hysteresis:	3 to 15 %	
LED:	Yes	
Options:	Cable length, Cable type	

These sensors share the following specifications:

- | | |
|--|--|
| <ul style="list-style-type: none"> * The EMC (Electromagnetic Compatibility) resistance of the switches:
IEC 61000-4-2 Level 2 IEC 61000-4-4 Level 2 IEC 61000-4-3 Level 2 IEC 60255-5 1 kV * Sensing range can vary +/-20 %. * Voltage spikes (300 V for 1 ms, 10 Hz) * All standard cables are 3 x 0.25 mm² and a length of 2 m. * Output capacity is 100 nF. * Storage temperature -13 °F to + 176 °F (-25 °C to 80 °C). * Relative humidity is 100 %. | <ul style="list-style-type: none"> * Vibration resistant to 1 mm amplitude at 55 Hz. * Shock resistant to 10 g for a period of 11 ms. * Degree of protection (DIN 40 050) is IP67 (higher IP options may be available). * Reverse polarity protection is incorporated on the supply voltage. * Load resistor of 100 kOhm is incorporated. * Leakage current is 4 mA at 24 V supply voltage. * Residual ripple is 15 %. * Voltage drop is approximately 2 V when sensor is on. * Sensing face material is: LPC-Vectra. |
|--|--|

Wiring Diagram PNP NO/NC

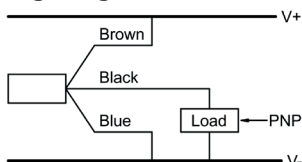

Special types and silicone free versions are available upon request

Wiring Diagram NPN NO/NC

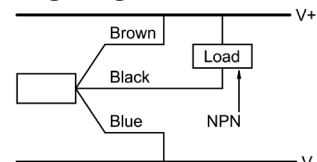

Design and technical details subject to change

Locon Sensor Systems, Inc.

HIGH TEMPERATURE INDUCTIVE PROXIMITY SENSORS

Sensing Distance: 4mm - Housing Diameter: M12

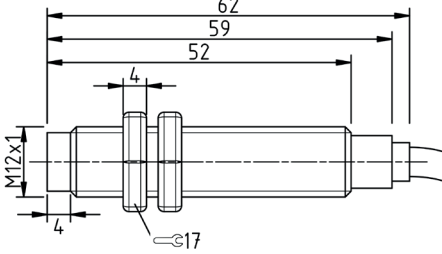

Dimensions are in mm.

Part Numbers:	
PNP/NO	IN4-12HTPS-150
PNP/NC	IN4-12HTPO-150
NPN/NO	IN4-12HTNS-150
NPN/NC	IN4-12HTNO-150

Technical Data:	
Mounting:	Unshielded
Sensing range in mm:	4
Supply voltage:	10-35 VDC
Output function:	N.O. or N.C.
Load current:	120 mA up to 266 °F (130 °C), 70 mA up to 302 °F (150 °C)
Switching Frequency:	500 Hz
Short circuit limit:	400 mA
Cable version:	Silicone
Operating temperature:	-13 to 356 °F (-25 to 150 °C)
Target size:	12 x 12 x 1 mm ST37
Hysteresis:	3 to 15 %
LED:	No
Options:	Cable length, Cable type

Dimensions are in mm.

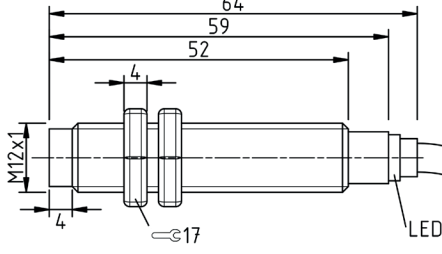
Part Numbers:	
PNP/NO	IN4-12HTPS/L-130
PNP/NC	IN4-12HTPO/L-130
NPN/NO	IN4-12HTNS/L-130
NPN/NC	IN4-12HTNO/L-130

Technical Data:		with LED
Mounting:	Unshielded	
Sensing range in mm:	4	
Supply voltage:	10-35 VDC	
Output function:	N.O. or N.C.	
Load current:	120 mA	
Switching Frequency:	500 Hz	
Short circuit limit:	400 mA	
Cable version:	Silicone	
Operating temperature:	-13 to 266 °F (-25 to 130 °C)	
Target size:	12 x 12 x 1 mm ST37	
Hysteresis:	3 to 15 %	
LED:	Yes	
Options:	Cable length, Cable type	

These sensors share the following specifications:

- | | |
|--|--|
| <ul style="list-style-type: none"> * The EMC (Electromagnetic Compatibility) resistance of the switches:
IEC 61000-4-2 Level 2 IEC 61000-4-4 Level 2 IEC 61000-4-3 Level 2 IEC 60255-5 1 kV * Sensing range can vary +/-20 %. * Voltage spikes (300 V for 1 ms, 10 Hz) * All standard cables are 3 x 0.25 mm² and a length of 2 m. * Output capacity is 100 nF. * Storage temperature -13 °F to + 176 °F (-25 °C to 80 °C). * Relative humidity is 100 %. | <ul style="list-style-type: none"> * Vibration resistant to 1 mm amplitude at 55 Hz. * Shock resistant to 10 g for a period of 11 ms. * Degree of protection (DIN 40 050) is IP67 (higher IP options may be available). * Reverse polarity protection is incorporated on the supply voltage. * Load resistor of 100 kOhm is incorporated. * Leakage current is 4 mA at 24 V supply voltage. * Residual ripple is 15 %. * Voltage drop is approximately 2 V when sensor is on. * Sensing face material is: LPC-Vectra. |
|--|--|

Wiring Diagram PNP NO/NC

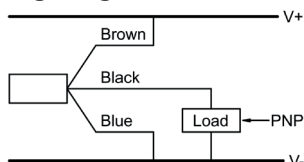

Special types and silicone free versions are available upon request

Wiring Diagram NPN NO/NC

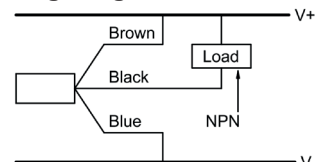

Design and technical details subject to change

Locon Sensor Systems, Inc.

HIGH TEMPERATURE INDUCTIVE PROXIMITY SENSORS

Sensing Distance: **5mm** - Housing Diameter: **M18**

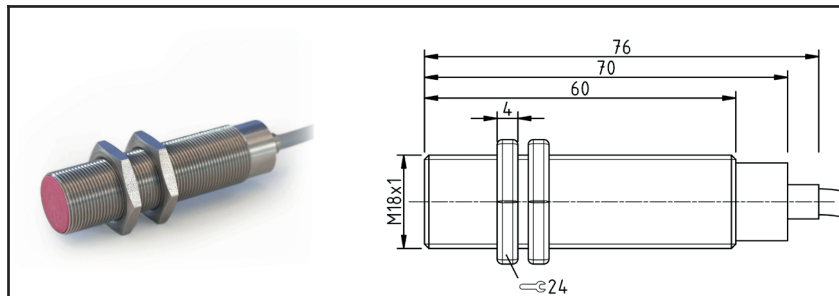

Dimensions are in mm.

Part Numbers:	
PNP/NO	IN5-18HTPS-180
PNP/NC	IN5-18HTPO-180
NPN/NO	IN5-18HTNS-180
NPN/NC	IN5-18HTNO-180

Technical Data:	
Mounting:	Shielded
Sensing range in mm:	5
Supply voltage:	10-35 VDC
Output function:	N.O. or N.C.
Load current:	120 mA
Switching Frequency:	400 Hz
Short circuit limit:	200 mA
Cable version:	Silicone
Operating temperature:	-40 to 356 °F (-40 to 180 °C)
Target size:	18 x 18 x 1 mm ST37
Hysteresis:	2 to 20 %
LED:	No
Options:	Cable length, Cable type

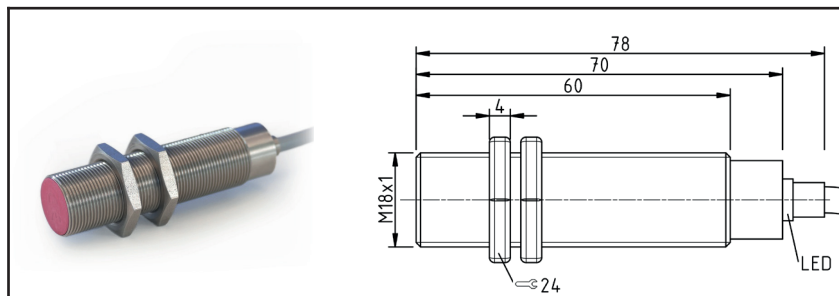

Dimensions are in mm.

Part Numbers:	
PNP/NO	IN5-18HTPS/L-130
PNP/NC	IN5-18HTPO/L-130
NPN/NO	IN5-18HTNS/L-130
NPN/NC	IN5-18HTNO/L-130

Technical Data: with LED	
Mounting:	Shielded
Sensing range in mm:	5
Supply voltage:	10-35 VDC
Output function:	N.O. or N.C.
Load current:	120 mA
Switching Frequency:	400 Hz
Short circuit limit:	200 mA
Cable version:	Silicone
Operating temperature:	-13 to 266 °F (-25 to 130 °C)
Target size:	18 x 18 x 1 mm ST37
Hysteresis:	2 to 20 %
LED:	Yes
Options:	Cable length, Cable type

These sensors share the following specifications:

- * The EMC (Electromagnetic Compatibility) resistance of the switches:
 - IEC 61000-4-2 Level 2
 - IEC 61000-4-3 Level 2
 - IEC 61000-4-4 Level 2
 - IEC 60255-5 1 kV
- * Sensing range can vary +/-20 %.
- * Voltage spikes (300 V for 1 ms, 10 Hz)
- * All standard cables are 3 x 0.25 mm² and a length of 2 m.
- * Output capacity is 100 nF.
- * Storage temperature -13 °F to + 176 °F (-25 °C to 80 °C).
- * Relative humidity is 100 %.
- * Vibration resistant to 1 mm amplitude at 55 Hz.
- * Shock resistant to 10 g for a period of 11 ms.
- * Degree of protection (DIN 40 050) is IP67 (higher IP options may be available).
- * Reverse polarity protection is incorporated on the supply voltage.
- * Load resistor of 100 kOhm is incorporated.
- * Leakage current is 4 mA at 24 V supply voltage.
- * Residual ripple is 15 %.
- * Voltage drop is approximately 2 V when sensor is on.
- * Sensing face material is: LPC-Vectra.

Wiring Diagram PNP NO/NC

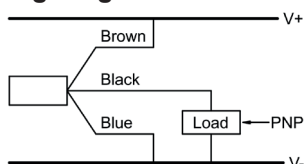

Wiring Diagram NPN NO/NC

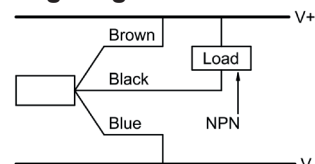

Special types and silicone free versions are available upon request

Design and technical details subject to change

Locon Sensor Systems, Inc.

HIGH TEMPERATURE INDUCTIVE PROXIMITY SENSORS

Sensing Distance: 5mm - Housing Diameter: M18



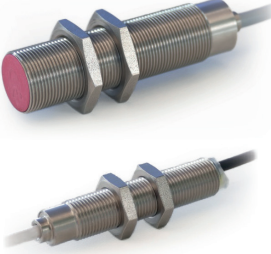

Dimensions are in mm.

Part Numbers:	
PNP/NO	IN5-18HTPS-230EXT
PNP/NC	IN5-18HTPO-230EXT
NPN/NO	IN5-18HTNS-230EXT
NPN/NC	IN5-18HTNO-230EXT

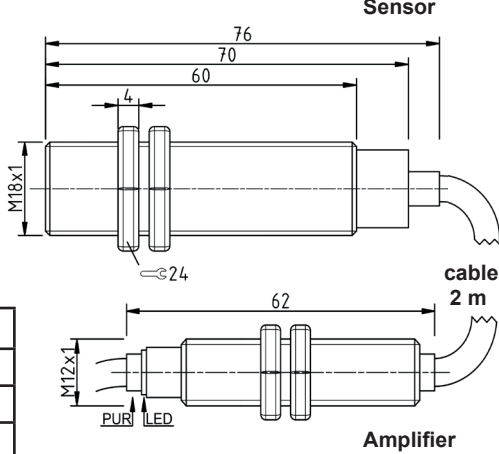

Sensor

76
60
4
M18x1
24
cable 2 m

Amplifier

62
M12x1
PUR LED

Technical Data:	External amplifier version
Mounting:	Shielded
Sensing range in mm:	5
Supply voltage:	10-35 VDC
Output function:	N.O. or N.C.
Load current:	120 mA
Switching Frequency:	400 Hz
Short circuit limit:	200 mA
Cable version:	Sensor: PTFE Amplifier: PUR
Operating temperature:	-13 to 446 °F (-25 to 230 °C)
Target size:	18 x 18 x 1 mm ST37
Hysteresis:	2 to 20 %
LED:	Yes (on amplifier)
Options:	Cable length and cable type

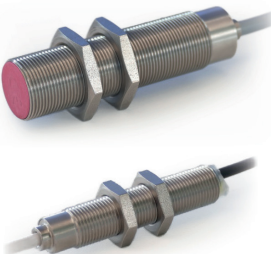

Dimensions are in mm.

Part Numbers:	
PNP/NO	IN5-18HTPS-250EXT
PNP/NC	IN5-18HTPO-250EXT
NPN/NO	IN5-18HTNS-250EXT
NPN/NC	IN5-18HTNO-250EXT

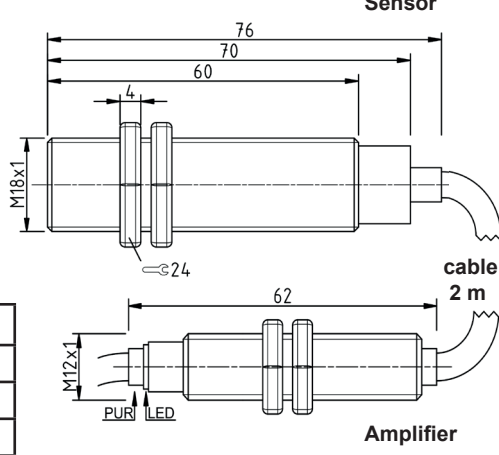

Sensor

76
70
60
4
M18x1
24
cable 2 m

Amplifier

62
M12x1
PUR LED

Technical Data:	External amplifier version
Mounting:	Shielded
Sensing range in mm:	5
Supply voltage:	10-35 VDC
Output function:	N.O. or N.C.
Load current:	120 mA
Switching Frequency:	400 Hz
Short circuit limit:	200 mA
Cable version:	Sensor: PTFE Amplifier: PUR
Operating temperature:	-13 to 482 °F (-25 to 250 °C)
Target size:	18 x 18 x 1 mm ST37
Hysteresis:	2 to 20 %
LED:	Yes (on amplifier)
Options:	Cable length, Cable type

These sensors share the following specifications:

- | | | | | | |
|--|-----------------------|-----------------------|-----------------------|------------------|---|
| <ul style="list-style-type: none"> * The EMC (Electromagnetic Compatibility) resistance of the switches: <table style="width: 100%; border: none;"> <tr> <td>IEC 61000-4-2 Level 2</td> <td>IEC 61000-4-4 Level 2</td> </tr> <tr> <td>IEC 61000-4-3 Level 2</td> <td>IEC 60255-5 1 kV</td> </tr> </table> * Sensing range can vary +/-20 %. * Voltage spikes (300 V for 1 ms, 10 Hz) * All standard cables are 3 x 0.25 mm² and a length of 2 m. * Output capacity is 100 nF. * Storage temperature -13 °F to +176 °F (-25 °C to 80 °C). * Relative humidity is 100 %. * Vibration resistant to 1 mm amplitude at 55 Hz. | IEC 61000-4-2 Level 2 | IEC 61000-4-4 Level 2 | IEC 61000-4-3 Level 2 | IEC 60255-5 1 kV | <ul style="list-style-type: none"> * Shock resistant to 10 g for a period of 11 ms. * Degree of protection (DIN 40 050) is IP67 (higher IP options may be available). * Reverse polarity protection is incorporated on the supply voltage. * Load resistor of 100 kOhm is incorporated. * Leakage current is 4 mA at 24 V supply voltage. * Residual ripple is 15 %. * Voltage drop is approximately 2 V when sensor is on. * Sensing face material is: LPC-Vectra. * Temperature specification for external amplifier: +14 to +158°F (-10 °C to 70 °C). |
| IEC 61000-4-2 Level 2 | IEC 61000-4-4 Level 2 | | | | |
| IEC 61000-4-3 Level 2 | IEC 60255-5 1 kV | | | | |

Wiring Diagram PNP NO/NC

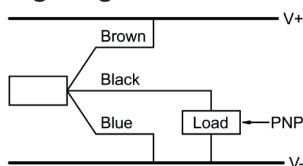

Wiring Diagram NPN NO/NC

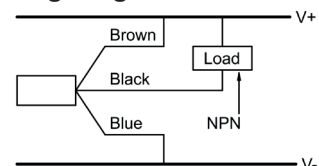

Special types and silicone free versions are available upon request

Design and technical details subject to change

Locon Sensor Systems, Inc.

HIGH TEMPERATURE INDUCTIVE PROXIMITY SENSORS

Sensing Distance: **5mm** - Housing Diameter: **M18**



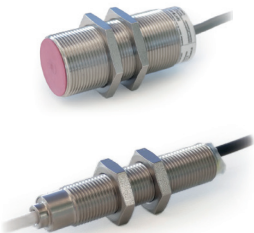

Dimensions are in mm.

Part Numbers:	
PNP/NO	IN5-1835HTPS-230EXT
PNP/NC	IN5-1835HTPO-230EXT
NPN/NO	IN5-1835HTNS-230EXT
NPN/NC	IN5-1835HTNO-230EXT

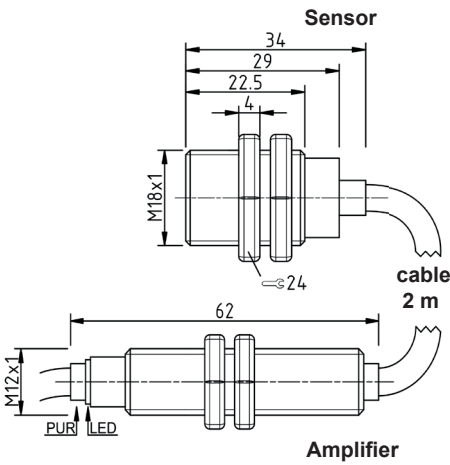

Sensor
34
29
22.5
4
M18x1
24
cable 2 m

Amplifier
62
M12x1
PUR LED

Technical Data:	External amplifier version
Mounting:	Shielded
Sensing range in mm:	5
Supply voltage:	10-35 VDC
Output function:	N.O. or N.C.
Load current:	120 mA
Switching Frequency:	400 Hz
Short circuit limit:	200 mA
Cable version:	Sensor: PTFE Amplifier: PUR
Operating temperature:	-13 to 446 °F (-25 to 230 °C)
Target size:	18 x 18 x 1 mm ST37
Hysteresis:	2 to 20 %
LED:	Yes (on amplifier)
Options:	Cable length and cable type

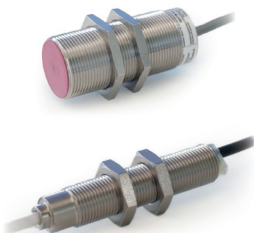

Dimensions are in mm.

Part Numbers:	
PNP/NO	IN5-1835HTPS-250EXT
PNP/NC	IN5-1835HTPO-250EXT
NPN/NO	IN5-1835HTNS-250EXT
NPN/NC	IN5-1835HTNO-250EXT

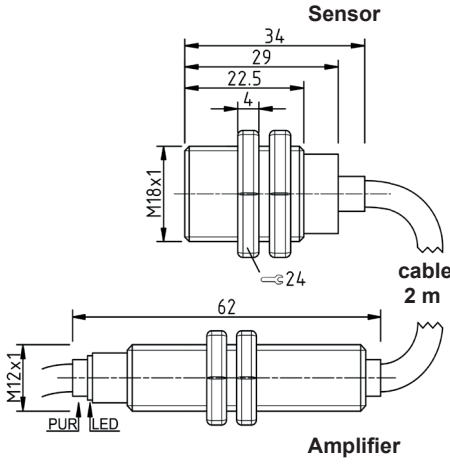

Sensor
34
29
22.5
4
M18x1
24
cable 2 m

Amplifier
62
M12x1
PUR LED

Technical Data:	External amplifier version
Mounting:	Shielded
Sensing range in mm:	5
Supply voltage:	10-35 VDC
Output function:	N.O. or N.C.
Load current:	120 mA
Switching Frequency:	400 Hz
Short circuit limit:	200 mA
Cable version:	Sensor: PTFE Amplifier: PUR
Operating temperature:	-13 to 482 °F (-25 to 250 °C)
Target size:	18 x 18 x 1 mm ST37
Hysteresis:	2 to 20 %
LED:	Yes (on amplifier)
Options:	Cable length, Cable type

These sensors share the following specifications:

- | | |
|--|---|
| <ul style="list-style-type: none"> * The EMC (Electromagnetic Compatibility) resistance of the switches:
IEC 61000-4-2 Level 2 IEC 61000-4-4 Level 2
IEC 61000-4-3 Level 2 IEC 60255-5 1 kV * Sensing range can vary +/-20 %. * Voltage spikes (300 V for 1 ms, 10 Hz) * All standard cables are 3 x 0.25 mm² and a length of 2 m. * Output capacity is 100 nF. * Storage temperature -13 °F to + 176 °F (-25 °C to 80 °C). * Relative humidity is 100 %. * Vibration resistant to 1 mm amplitude at 55 Hz. | <ul style="list-style-type: none"> * Shock resistant to 10 g for a period of 11 ms. * Degree of protection (DIN 40 050) is IP67 (higher IP options may be available). * Reverse polarity protection is incorporated on the supply voltage. * Load resistor of 100 kOhm is incorporated. * Leakage current is 4 mA at 24 V supply voltage. * Residual ripple is 15 %. * Voltage drop is approximately 2 V when sensor is on. * Sensing face material is: LPC-Vectra. * Temperature specification for external amplifier:
+14 to +158°F (-10 °C to 70 °C). |
|--|---|

Wiring Diagram PNP NO/NC

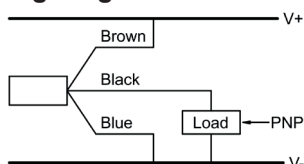

Wiring Diagram NPN NO/NC

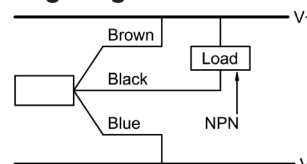

Special types and silicone free versions are available upon request

Design and technical details subject to change

Locon Sensor Systems, Inc.

HIGH TEMPERATURE INDUCTIVE PROXIMITY SENSORS

Sensing Distance: 8mm - Housing Diameter: M18

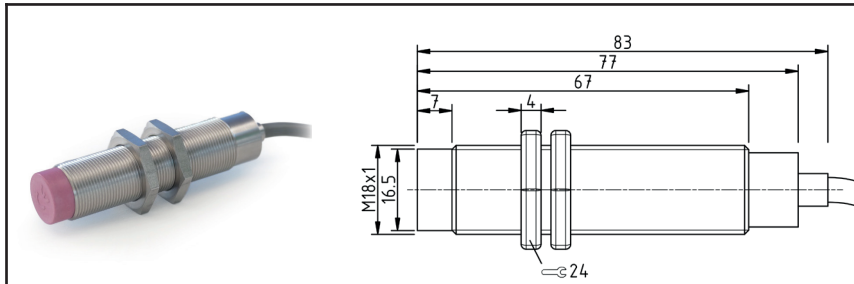

Dimensions are in mm.

Part Numbers:	
PNP/NO	IN8-18HTPS-180
PNP/NC	IN8-18HTPO-180
NPN/NO	IN8-18HTNS-180
NPN/NC	IN8-18HTNO-180

Technical Data:	
Mounting:	Unshielded
Sensing range in mm:	8
Supply voltage:	10-35 VDC
Output function:	N.O. or N.C.
Load current:	120 mA
Switching Frequency:	400 Hz
Short circuit limit:	200 mA
Cable version:	Silicone
Operating temperature:	-13 to 356 °F (-25 to 180 °C)
Target size:	18 x 18 x 1 mm ST37
Hysteresis:	3 to 15 %
LED:	No
Options:	Cable length, Cable type

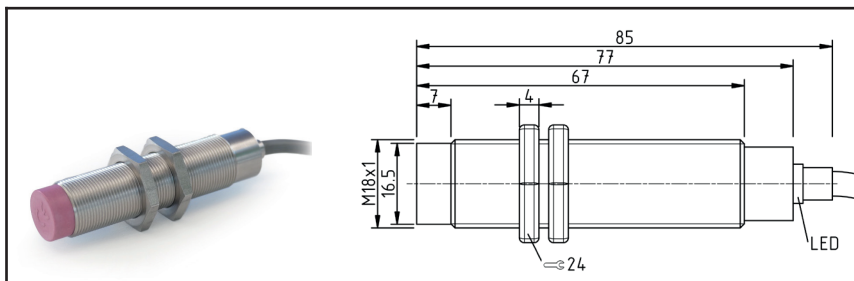

Dimensions are in mm.

Part Numbers:	
PNP/NO	IN8-18HTPS/L-130
PNP/NC	IN8-18HTPO/L-130
NPN/NO	IN8-18HTNS/L-130
NPN/NC	IN8-18HTNO/L-130

Technical Data: with LED	
Mounting:	Unshielded
Sensing range in mm:	8
Supply voltage:	10-35 VDC
Output function:	N.O. or N.C.
Load current:	120 mA
Switching Frequency:	400 Hz
Short circuit limit:	200 mA
Cable version:	Silicone
Operating temperature:	-13 to 266 °F (-25 to 130 °C)
Target size:	18 x 18 x 1 mm ST37
Hysteresis:	3 to 15 %
LED:	Yes
Options:	Cable length, Cable type

These sensors share the following specifications:

- * The EMC (Electromagnetic Compatibility) resistance of the switches:
 - IEC 61000-4-2 Level 2
 - IEC 61000-4-3 Level 2
 - IEC 61000-4-4 Level 2
 - IEC 60255-5 1 kV
- * Sensing range can vary +/-20 %.
- * Voltage spikes (300 V for 1 ms, 10 Hz)
- * All standard cables are 3 x 0.25 mm² and a length of 2 m.
- * Output capacity is 100 nF.
- * Storage temperature -13 °F to + 176 °F (-25 °C to 80 °C).
- * Relative humidity is 100 %.
- * Vibration resistant to 1 mm amplitude at 55 Hz.
- * Shock resistant to 10 g for a period of 11 ms.
- * Degree of protection (DIN 40 050) is IP67 (higher IP options may be available).
- * Reverse polarity protection is incorporated on the supply voltage.
- * Load resistor of 100 kOhm is incorporated.
- * Leakage current is 4 mA at 24 V supply voltage.
- * Residual ripple is 15 %.
- * Voltage drop is approximately 2 V when sensor is on.
- * Sensing face material is: LPC-Vectra.

Wiring Diagram PNP NO/NC

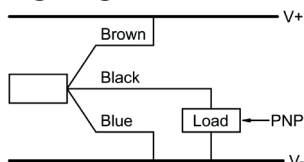

Wiring Diagram NPN NO/NC

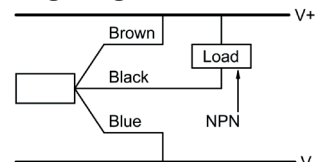

Special types and silicone free versions are available upon request

Design and technical details subject to change

Locon Sensor Systems, Inc.

HIGH TEMPERATURE INDUCTIVE PROXIMITY SENSORS

Sensing Distance: 10mm - Housing Diameter: M30



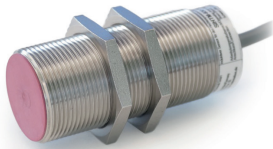

Dimensions are in mm.

Part Numbers:	
PNP/NO	IN10-30HTPS-180
PNP/NC	IN10-30HTPO-180
NPN/NO	IN10-30HTNS-180
NPN/NC	IN10-30HTNO-180

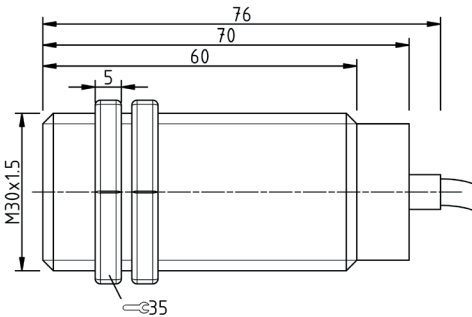

Technical Data:	
Mounting:	Shielded
Sensing range in mm:	10
Supply voltage:	10-35 VDC
Output function:	N.O. or N.C.
Load current:	120 mA
Switching Frequency:	200 Hz
Short circuit limit:	200 mA
Cable version:	Silicone
Operating temperature:	-40 to 356 °F (-40 to 180 °C)
Target size:	30 x 30 x 1 mm ST37
Hysteresis:	3 to 15 %
LED:	No
Options:	Cable length, Cable type, Connector

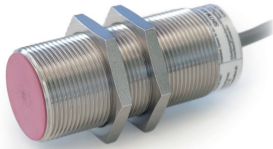

Dimensions are in mm.

Part Numbers:	
PNP/NO	IN10-30HTPS/L-130
PNP/NC	IN10-30HTPO/L-130
NPN/NO	IN10-30HTNS/L-130
NPN/NC	IN10-30HTNO/L-130

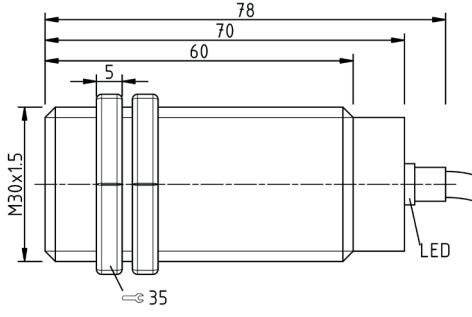

Technical Data:		with LED
Mounting:	Shielded	
Sensing range in mm:	10	
Supply voltage:	10-35 VDC	
Output function:	N.O. or N.C.	
Load current:	120 mA	
Switching Frequency:	200 Hz	
Short circuit limit:	200 mA	
Cable version:	Silicone	
Operating temperature:	-13 to 266 °F (-25 to 130 °C)	
Target size:	30 x 30 x 1 mm ST37	
Hysteresis:	3 to 15 %	
LED:	Yes	
Options:	Cable length, Cable type, Connector	

These sensors share the following specifications:

- | | |
|--|---|
| <ul style="list-style-type: none"> * The EMC (Electromagnetic Compatibility) resistance of the switches: <ul style="list-style-type: none"> IEC 61000-4-2 Level 2 IEC 61000-4-3 Level 2 * Sensing range can vary +/-20 %. * Voltage spikes (300 V for 1 ms, 10 Hz) * All standard cables are 3 x 0.25 mm² and a length of 2 m. * Output capacity is 100 nF. * Storage temperature -13 °F to + 176 °F (-25 °C to 80 °C). * Relative humidity is 100 %. | <ul style="list-style-type: none"> * IEC 61000-4-4 Level 2 * IEC 60255-5 1 kV * Vibration resistant to 1 mm amplitude at 55 Hz. * Shock resistant to 10 g for a period of 11 ms. * Degree of protection (DIN 40 050) is IP67 (higher IP options may be available). * Reverse polarity protection is incorporated on the supply voltage. * Load resistor of 100 kOhm is incorporated. * Leakage current is 4 mA at 24 V supply voltage. * Residual ripple is 15 %. * Voltage drop is approximately 2 V when sensor is on. * Sensing face material is: LPC-Vectra. |
|--|---|

Wiring Diagram PNP NO/NC

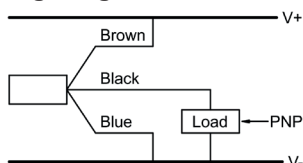

Special types and silicone free versions are available upon request

Wiring Diagram NPN NO/NC

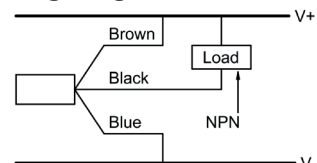

Design and technical details subject to change

Locon Sensor Systems, Inc.

HIGH TEMPERATURE INDUCTIVE PROXIMITY SENSORS

Sensing Distance: 10 mm - Housing Diameter: M30



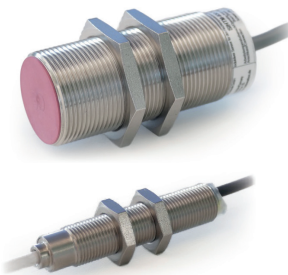

Dimensions are in mm.

Part Numbers:	
PNP/NO	IN10-30HTPS-230EXT
PNP/NC	IN10-30HTPO-230EXT
NPN/NO	IN10-30HTNS-230EXT
NPN/NC	IN10-30HTNO-230EXT

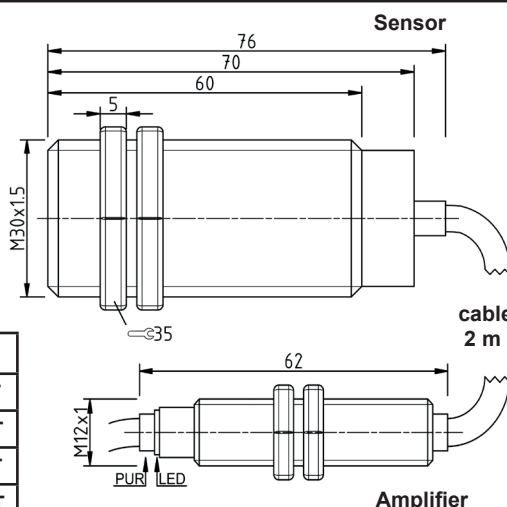

Sensor

Amplifier

Technical Data:	External amplifier version
Mounting:	Shielded
Sensing range in mm:	10
Supply voltage:	10-35 VDC
Output function:	N.O. or N.C.
Load current:	120 mA
Switching Frequency:	200 Hz
Short circuit limit:	200 mA
Cable version:	Sensor: PTFE Amplifier: PUR
Operating temperature:	-13 to 446 °F (-25 to 230 °C)
Target size:	30 x 30 x 1 mm ST37
Hysteresis:	3 to 15 %
LED:	Yes (on amplifier)
Options:	Cable length, Cable type, Connector

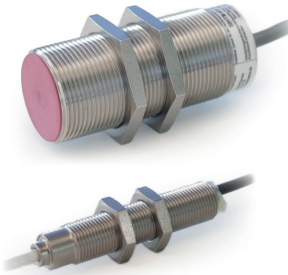

Dimensions are in mm.

Part Numbers:	
PNP/NO	IN10-30HTPS-250EXT
PNP/NC	IN10-30HTPO-250EXT
NPN/NO	IN10-30HTNS-250EXT
NPN/NC	IN10-30HTNO-250EXT

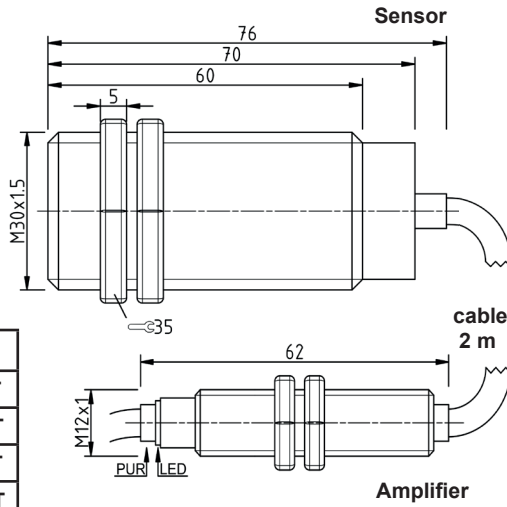

Sensor

Amplifier

Technical Data:	External amplifier version
Mounting:	Shielded
Sensing range in mm:	10
Supply voltage:	10-35 VDC
Output function:	N.O. or N.C.
Load current:	120 mA
Switching Frequency:	200 Hz
Short circuit limit:	200 mA
Cable version:	Sensor: PTFE Amplifier: PUR
Operating temperature:	-13 to 482 °F (-25 to 250 °C)
Target size:	30 x 30 x 1 mm ST37
Hysteresis:	3 to 15 %
LED:	Yes (on amplifier)
Options:	Cable length, Cable type, Connector

These sensors share the following specifications:

- * The EMC (Electromagnetic Compatibility) resistance of the switches:
 - IEC 61000-4-2 Level 2
 - IEC 61000-4-3 Level 2
 - IEC 61000-4-4 Level 2
 - IEC 60255-5 1 kV
- * Sensing range can vary +/-20 %.
- * Voltage spikes (300 V for 1 ms, 10 Hz)
- * All standard cables are 3 x 0.25 mm² and a length of 2 m.
- * Output capacity is 100 nF.
- * Storage temperature -13 °F to +176 °F (-25 °C to 80 °C).
- * Relative humidity is 100 %.
- * Vibration resistant to 1 mm amplitude at 55 Hz.
- * Shock resistant to 10 g for a period of 11 ms.
- * Degree of protection (DIN 40 050) is IP67 (higher IP options may be available).
- * Reverse polarity protection is incorporated on the supply voltage.
- * Load resistor of 100 kOhm is incorporated.
- * Leakage current is 4 mA at 24 V supply voltage.
- * Residual ripple is 15 %.
- * Voltage drop is approximately 2 V when sensor is on.
- * Sensing face material is: LPC-Vectra.
- * Temperature specification for external amplifier: +14 to +158°F (-10 °C to 70 °C).

Wiring Diagram PNP NO/NC

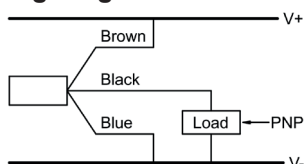

Wiring Diagram NPN NO/NC

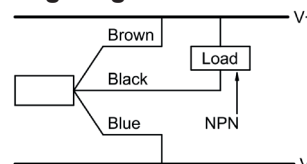

Special types and silicone free versions are available upon request

Design and technical details subject to change

Locon Sensor Systems, Inc.

HIGH TEMPERATURE INDUCTIVE PROXIMITY SENSORS

Sensing Distance: 15mm - Housing Diameter: M30



Dimensions are in mm.

Part Numbers:	
PNP/NO	IN15-30HTPS-180
PNP/NC	IN15-30HTPO-180
NPN/NO	IN15-30HTNS-180
NPN/NC	IN15-30HTNO-180

Technical Data:	
Mounting:	Unshielded
Sensing range in mm:	15
Supply voltage:	10-35 VDC
Output function:	N.O. or N.C.
Load current:	120 mA
Switching Frequency:	200 Hz
Short circuit limit:	200 mA
Cable version:	Silicone
Operating temperature:	-13 to 356 °F (-25 to 180 °C)
Target size:	30 x 30 x 1 mm ST37
Hysteresis:	3 to 15 %
LED:	No
Options:	Cable length, Cable type, Connector

Dimensions are in mm.

Part Numbers:	
PNP/NO	IN15-30HTPS/L-130
PNP/NC	IN15-30HTPO/L-130
NPN/NO	IN15-30HTNS/L-130
NPN/NC	IN15-30HTNO/L-130

Technical Data:		with LED
Mounting:	Unshielded	
Sensing range in mm:	15	
Supply voltage:	10-35 VDC	
Output function:	N.O. or N.C.	
Load current:	120 mA	
Switching Frequency:	200 Hz	
Short circuit limit:	200 mA	
Cable version:	Silicone	
Operating temperature:	-13 to 266 °F (-25 to 130 °C)	
Target size:	30 x 30 x 1 mm ST37	
Hysteresis:	3 to 15 %	
LED:	Yes	
Options:	Cable length, Cable type, Connector	

These sensors share the following specifications:

- | | | | | | |
|--|-----------------------|-----------------------|-----------------------|------------------|--|
| <ul style="list-style-type: none"> * The EMC (Electromagnetic Compatibility) resistance of the switches: <table border="0"> <tr> <td>IEC 61000-4-2 Level 2</td> <td>IEC 61000-4-4 Level 2</td> </tr> <tr> <td>IEC 61000-4-3 Level 2</td> <td>IEC 60255-5 1 kV</td> </tr> </table> * Sensing range can vary +/-20 %. * Voltage spikes (300 V for 1 ms, 10 Hz) * All standard cables are 3 x 0.25 mm² and a length of 2 m. * Output capacity is 100 nF. * Storage temperature -13 °F to + 176 °F (-25 °C to 80 °C). * Relative humidity is 100 %. | IEC 61000-4-2 Level 2 | IEC 61000-4-4 Level 2 | IEC 61000-4-3 Level 2 | IEC 60255-5 1 kV | <ul style="list-style-type: none"> * Vibration resistant to 1 mm amplitude at 55 Hz. * Shock resistant to 10 g for a period of 11 ms. * Degree of protection (DIN 40 050) is IP67 (higher IP options may be available). * Reverse polarity protection is incorporated on the supply voltage. * Load resistor of 100 kOhm is incorporated. * Leakage current is 4 mA at 24 V supply voltage. * Residual ripple is 15 %. * Voltage drop is approximately 2 V when sensor is on. * Sensing face material is: LPC-Vectra. |
| IEC 61000-4-2 Level 2 | IEC 61000-4-4 Level 2 | | | | |
| IEC 61000-4-3 Level 2 | IEC 60255-5 1 kV | | | | |

Wiring Diagram PNP NO/NC

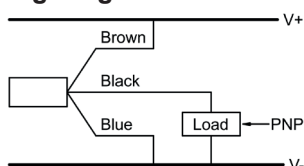

Special types and silicone free versions are available upon request

Wiring Diagram NPN NO/NC

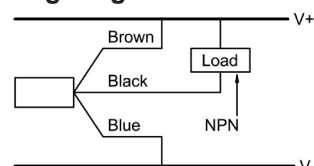

Design and technical details subject to change

Locon Sensor Systems, Inc.

HIGH TEMPERATURE INDUCTIVE PROXIMITY SENSORS

Sensing Distance: 15mm - Housing Diameter: M30



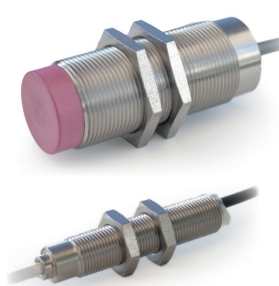

Dimensions are in mm.

Part Numbers:	
PNP/NO	IN15-30HTPS-230EXT
PNP/NC	IN15-30HTPO-230EXT
NPN/NO	IN15-30HTNS-230EXT
NPN/NC	IN15-30HTNO-230EXT

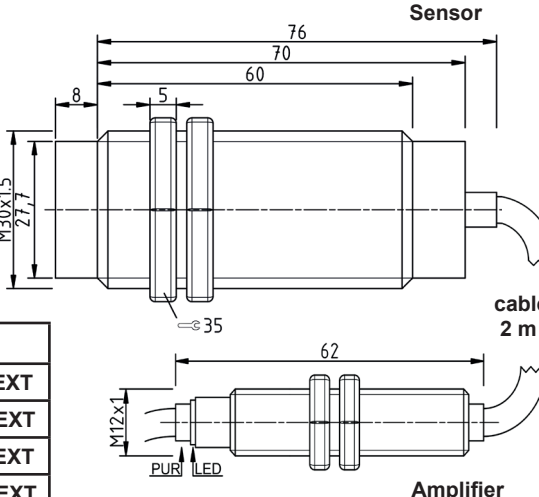

Sensor

76, 70, 60, 8, 5, M30x1.5, 27.7, 35, cable 2 m

Amplifier

62, M12x1, PUR, LED

Technical Data:	External amplifier version
Mounting:	Unshielded
Sensing range in mm:	15
Supply voltage:	10-35 VDC
Output function:	N.O. or N.C.
Load current:	120 mA
Switching Frequency:	200 Hz
Short circuit limit:	200 mA
Cable version:	Sensor: PTFE Amplifier: PUR
Operating temperature:	-13 to 446 °F (-25 to 230 °C)
Target size:	30 x 30 x 1 mm ST37
Hysteresis:	3 to 15 %
LED:	Yes (on amplifier)
Options:	Cable length, Cable type, Connector

This sensor has the following specifications:

* The EMC (Electromagnetic Compatibility) resistance of the switches: IEC 61000-4-2 Level 2 IEC 61000-4-3 Level 2	IEC 61000-4-4 Level 2 IEC 60255-5 1 kV	* Shock resistant to 10 g for a period of 11 ms. * Degree of protection (DIN 40 050) is IP67 (higher IP options may be available). * Reverse polarity protection is incorporated on the supply voltage. * Load resistor of 100 kOhm is incorporated. * Leakage current is 4 mA at 24 V supply voltage. * Residual ripple is 15 %. * Voltage drop is approximately 2 V when sensor is on. * Sensing face material is: LPC-Vectra. * Temperature specification for external amplifier: +14 to +158°F (-10 °C to 70 °C).
* Sensing range can vary +/-20 %. * Voltage spikes (300 V for 1 ms, 10 Hz) * All standard cables are 3 x 0.25 mm ² and a length of 2 m. * Output capacity is 100 nF. * Storage temperature -13 °F to + 176 °F (-25 °C to 80 °C). * Relative humidity is 100 %. * Vibration resistant to 1 mm amplitude at 55 Hz.		

Wiring Diagram PNP NO/NC

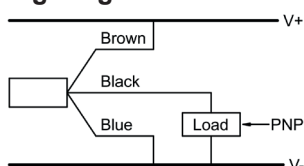

Wiring Diagram NPN NO/NC

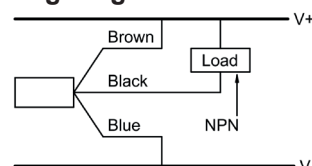

Special types and silicone free versions are available upon request

Design and technical details subject to change

Locon Sensor Systems, Inc.

HIGH TEMPERATURE INDUCTIVE PROXIMITY SENSORS

Sensing Distance: 20 mm - Housing Diameter: M50



Dimensions are in mm.

Part Numbers:	
PNP/NO	IN20-50HTPS-180
PNP/NC	IN20-50HTPO-180
NPN/NO	IN20-50HTNS-180
NPN/NC	IN20-50HTNO-180

Technical Data:	
Mounting:	Shielded
Sensing range in mm:	20
Supply voltage:	10-35 VDC
Output function:	N.O. or N.C.
Load current:	120 mA
Switching Frequency:	200 Hz
Short circuit limit:	200 mA
Cable version:	Silicone
Operating temperature:	-13 to 356 °F (-25 to 180 °C)
Target size:	50 x 50 x 1 mm ST37
Hysteresis:	3 to 20 %
LED:	No
Options:	Cable length, Cable type, Connector

Dimensions are in mm.

Part Numbers:	
PNP/NO	IN20-50HTPS/L-130
PNP/NC	IN20-50HTPO/L-130
NPN/NO	IN20-50HTNS/L-130
NPN/NC	IN20-30HTNO/L-130

Technical Data:		with LED
Mounting:	Shielded	
Sensing range in mm:	20	
Supply voltage:	10-35 VDC	
Output function:	N.O. or N.C.	
Load current:	120 mA	
Switching Frequency:	200 Hz	
Short circuit limit:	200 mA	
Cable version:	Silicone	
Operating temperature:	-13 to 266 °F (-25 to 130 °C)	
Target size:	50 x 50 x 1 mm ST37	
Hysteresis:	3 to 20 %	
LED:	Yes	
Options:	Cable length, Cable type, Connector	

These sensors share the following specifications:

- * The EMC (Electromagnetic Compatibility) resistance of the switches:
 - IEC 61000-4-2 Level 2
 - IEC 61000-4-3 Level 2
 - IEC 61000-4-4 Level 2
 - IEC 60255-5 1 kV
- * Sensing range can vary +/-20 %.
- * Voltage spikes (300 V for 1 ms, 10 Hz)
- * All standard cables are 3 x 0.25 mm² and a length of 2 m.
- * Output capacity is 100 nF.
- * Storage temperature -13 °F to +176 °F (-25 °C to 80 °C).
- * Relative humidity is 100 %.
- * Vibration resistant to 1 mm amplitude at 55 Hz.
- * Shock resistant to 5 g for a period of 11 ms.
- * Degree of protection (DIN 40 050) is IP67 (higher IP options may be available).
- * Reverse polarity protection is incorporated on the supply voltage.
- * Load resistor of 100 kOhm is incorporated.
- * Leakage current is 4 mA at 24 V supply voltage.
- * Residual ripple is 15 %.
- * Voltage drop is approximately 2 V when sensor is on.
- * Sensing face material is: LPC-Vectra.

Wiring Diagram PNP NO/NC

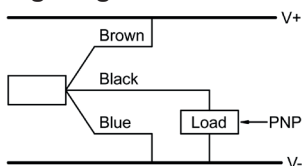

Special types and silicone free versions are available upon request

Wiring Diagram NPN NO/NC

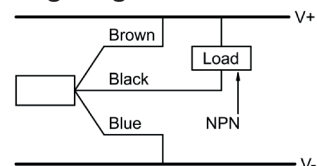

Design and technical details subject to change

Locon Sensor Systems, Inc.

HIGH TEMPERATURE INDUCTIVE PROXIMITY SENSORS

Sensing Distance: 20 mm - Housing Diameter: M50



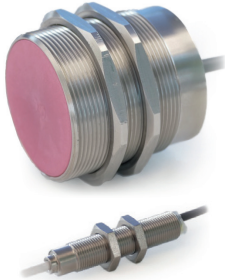

Dimensions are in mm.

Part Numbers:	
PNP/NO	IN20-50HTPS-230EXT
PNP/NC	IN20-50HTPO-230EXT
NPN/NO	IN20-50HTNS-230EXT
NPN/NC	IN20-50HTNO-230EXT

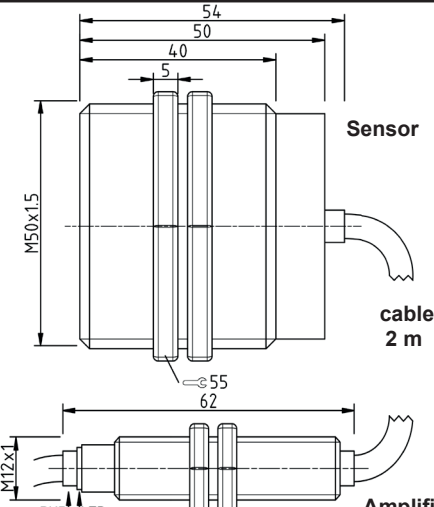

Sensor
54, 50, 40, 5, M50x1.5, cable 2 m, 55, 62

Amplifier
M12x1, PUR, LED

Technical Data:	External amplifier version
Mounting:	Shielded
Sensing range in mm:	20
Supply voltage:	10-35 VDC
Output function:	N.O. or N.C.
Load current:	120 mA
Switching Frequency:	200 Hz
Short circuit limit:	200 mA
Cable version:	Sensor: PTFE Amplifier: PUR
Operating temperature:	-13 to 446 °F (-25 to 230 °C)
Target size:	50 x 50 x 1 mm ST37
Hysteresis:	3 to 20 %
LED:	Yes (on amplifier)
Options:	Cable length, Cable type, Connector

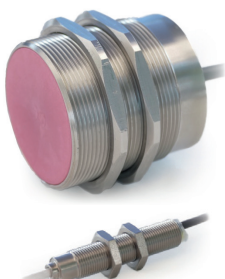

Dimensions are in mm.

Part Numbers:	
PNP/NO	IN20-50HTPS-250EXT
PNP/NC	IN20-50HTPO-250EXT
NPN/NO	IN20-50HTNS-250EXT
NPN/NC	IN20-50HTNO-250EXT

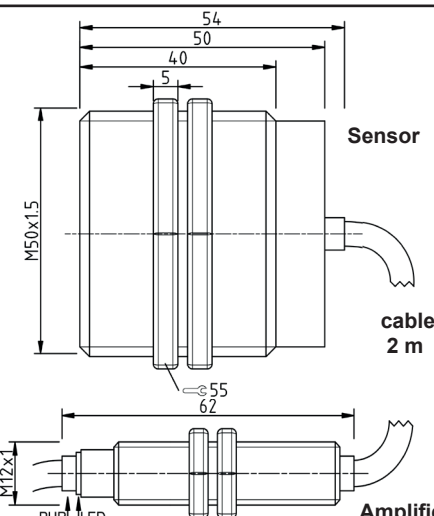

Sensor
54, 50, 40, 5, M50x1.5, cable 2 m, 55, 62

Amplifier
M12x1, PUR, LED

Technical Data:	External amplifier version
Mounting:	Shielded
Sensing range in mm:	20
Supply voltage:	10-35 VDC
Output function:	N.O. or N.C.
Load current:	120 mA
Switching Frequency:	200 Hz
Short circuit limit:	200 mA
Cable version:	Sensor: PTFE Amplifier: PUR
Operating temperature:	-13 to 482 °F (-25 to 250 °C)
Target size:	50 x 50 x 1 mm ST37
Hysteresis:	3 to 20 %
LED:	Yes (on amplifier)
Options:	Cable length, Cable type, Connector

These sensors share the following specifications:

- * The EMC (Electromagnetic Compatibility) resistance of the switches:
 - IEC 61000-4-2 Level 2
 - IEC 61000-4-3 Level 2
 - IEC 61000-4-4 Level 2
 - IEC 60255-5 1 kV
- * Sensing range can vary +/-20 %.
- * Voltage spikes (300 V for 1 ms, 10 Hz)
- * All standard cables are 3 x 0.25 mm² and a length of 2 m.
- * Output capacity is 100 nF.
- * Storage temperature -13 °F to +176 °F (-25 °C to 80 °C).
- * Relative humidity is 100 %.
- * Vibration resistant to 1 mm amplitude at 55 Hz.
- * Shock resistant to 5 g for a period of 11 ms.
- * Degree of protection (DIN 40 050) is IP67 (higher IP options may be available).
- * Reverse polarity protection is incorporated on the supply voltage.
- * Load resistor of 100 kOhm is incorporated.
- * Leakage current is 4 mA at 24 V supply voltage.
- * Residual ripple is 15 %.
- * Voltage drop is approximately 2 V when sensor is on.
- * Sensing face material is: LPC-Vectra.
- * Temperature specification for external amplifier: +14 to +158°F (-10 °C to 70 °C).

Wiring Diagram PNP NO/NC

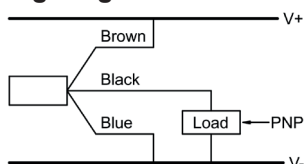

Wiring Diagram NPN NO/NC

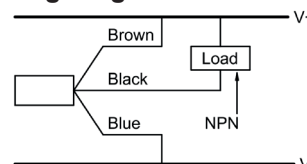

Special types and silicone free versions are available upon request

Design and technical details subject to change

Locon Sensor Systems, Inc.

HIGH TEMPERATURE INDUCTIVE PROXIMITY SENSORS

Sensing Distance: 30 mm - Housing Diameter: M50



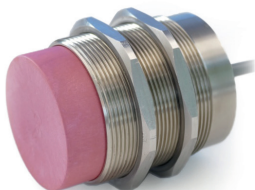

Dimensions are in mm.

Part Numbers:	
PNP/NO	IN30-50HTPS-180
PNP/NC	IN30-50HTPO-180
NPN/NO	IN30-50HTNS-180
NPN/NC	IN30-50HTNO-180

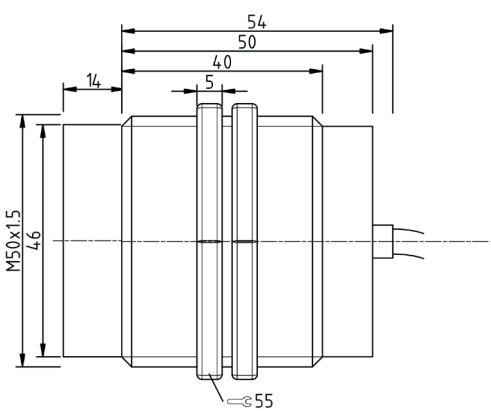

Technical Data:	
Mounting:	Unshielded
Sensing range in mm:	30
Supply voltage:	10-35 VDC
Output function:	N.O. or N.C.
Load current:	120 mA
Switching Frequency:	50 Hz
Short circuit limit:	200 mA
Cable version:	Silicone
Operating temperature:	-13 to 356 °F (-25 to 180 °C)
Target size:	50 x 50 x 1 mm ST37
Hysteresis:	3 to 20 %
LED:	No
Options:	Cable length, Cable type, Connector

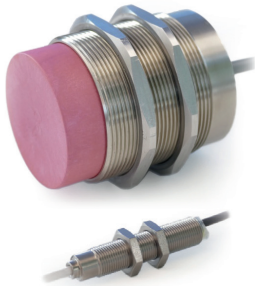

Dimensions are in mm.

Part Numbers:	
PNP/NO	IN30-50HTPS-230EXT
PNP/NC	IN30-50HTPO-230EXT
NPN/NO	IN30-50HTNS-230EXT
NPN/NC	IN30-50HTNO-230EXT

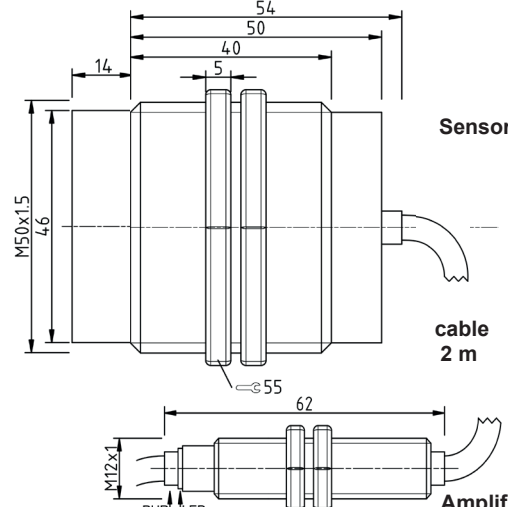

Technical Data:		External amplifier version
Mounting:	Unshielded	
Sensing range in mm:	30	
Supply voltage:	10-35 VDC	
Output function:	N.O. or N.C.	
Load current:	120 mA	
Switching Frequency:	50 Hz	
Short circuit limit:	200 mA	
Cable version:	Sensor: PTFE	Amplifier: PUR
Operating temperature:	-13 to 446 °F (-25 to 230 °C)	
Target size:	50 x 50 x 1 mm ST37	
Hysteresis:	3 to 20 %	
LED:	Yes (on amplifier)	
Options:	Cable length, Cable type, Connector	

These sensors share the following specifications:

- * The EMC (Electromagnetic Compatibility) resistance of the switches:
 - IEC 61000-4-2 Level 2
 - IEC 61000-4-3 Level 2
 - IEC 61000-4-4 Level 2
 - IEC 60255-5 1 kV
- * Sensing range can vary +/-20 %.
- * Voltage spikes (300 V for 1 ms, 10 Hz)
- * All standard cables are 3 x 0.25 mm² and a length of 2 m.
- * Output capacity is 100 nF.
- * Storage temperature -13 °F to +176 °F (-25 °C to 80 °C).
- * Relative humidity is 100 %.
- * Vibration resistant to 1 mm amplitude at 55 Hz.
- * Shock resistant to 5 g for a period of 11 ms.
- * Degree of protection (DIN 40 050) is IP67 (higher IP options may be available).
- * Reverse polarity protection is incorporated on the supply voltage.
- * Load resistor of 100 kOhm is incorporated.
- * Leakage current is 4 mA at 24 V supply voltage.
- * Residual ripple is 15 %.
- * Voltage drop is approximately 2 V when sensor is on.
- * Sensing face material is: LPC-Vectra.
- * Temperature specification for external amplifier: +14 to +158°F (-10 °C to 70 °C).

Wiring Diagram PNP NO/NC

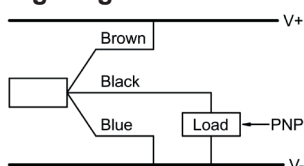

Wiring Diagram NPN NO/NC

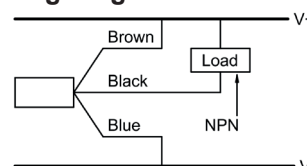

Special types and silicone free versions are available upon request

Design and technical details subject to change

Locon Sensor Systems, Inc.

HIGH TEMPERATURE INDUCTIVE PROXIMITY SENSORS

Sensing Distance: 50 mm - Housing Diameter: M80



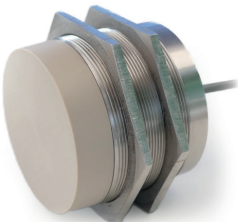

Dimensions are in mm.

Part Numbers:	
PNP/NO	IN50-80HTPS-160
PNP/NC	IN50-80HTPO-160
NPN/NO	IN50-80HTNS-160
NPN/NC	IN50-80HTNO-160

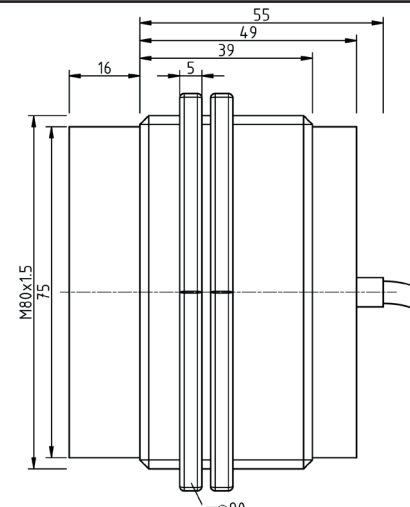

Technical Data:	
Mounting:	Unshielded
Sensing range in mm:	50
Supply voltage:	10-35 VDC
Output function:	N.O. or N.C.
Load current:	120 mA
Switching Frequency:	50 Hz
Short circuit limit:	200 mA
Cable version:	Silicone
Operating temperature:	-13 to 356 °F (-25 to 180 °C)
Target size:	80 x 80 x 1 mm ST37
Hysteresis:	3 to 20 %
LED:	No
Options:	Cable length, Cable type, Connector

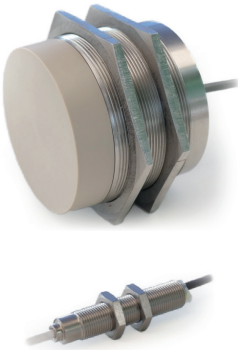

Dimensions are in mm.

Part Numbers:	
PNP/NO	IN50-80HTPS-230EXT
PNP/NC	IN50-80HTPO-230EXT
NPN/NO	IN50-80HTNS-230EXT
NPN/NC	IN50-80HTNO-230EXT

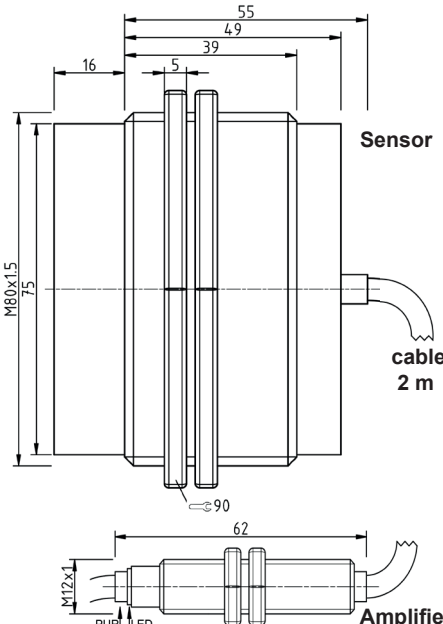

Technical Data:		External amplifier version	
Mounting:	Unshielded		
Sensing range in mm:	50		
Supply voltage:	10-35 VDC		
Output function:	N.O. or N.C.		
Load current:	120 mA		
Switching Frequency:	50 Hz		
Short circuit limit:	200 mA		
Cable version:	Sensor: PTFE Amplifier: PUR		
Operating temperature:	-13 to 266 °F (-25 to 130 °C)		
Target size:	50 x 50 x 1 mm ST37		
Hysteresis:	3 to 20 %		
LED:	Yes (on amplifier)		
Options:	Cable length, Cable type, Connector		

These sensors share the following specifications:

- * The EMC (Electromagnetic Compatibility) resistance of the switches:
 - IEC 61000-4-2 Level 2
 - IEC 61000-4-3 Level 2
 - IEC 61000-4-4 Level 2
 - IEC 60255-5 1 kV
- * Sensing range can vary +/-20 %.
- * Voltage spikes (300 V for 1 ms, 10 Hz)
- * All standard cables are 3 x 0.25 mm² and a length of 2 m.
- * Output capacity is 100 nF.
- * Storage temperature -13 °F to +176 °F (-25 °C to 80 °C).
- * Relative humidity is 100 %.
- * Vibration resistant to 1 mm amplitude at 55 Hz.
- * Shock resistant to 5 g for a period of 11 ms.
- * Degree of protection (DIN 40 050) is IP67 (higher IP options may be available).
- * Reverse polarity protection is incorporated on the supply voltage.
- * Load resistor of 100 kOhm is incorporated.
- * Leakage current is 4 mA at 24 V supply voltage.
- * Residual ripple is 15 %.
- * Voltage drop is approximately 2 V when sensor is on.
- * Sensing face material is: LPC-Vectra.
- * Temperature specification for external amplifier: +14 to +158°F (-10 °C to 70 °C).

Wiring Diagram PNP NO/NC

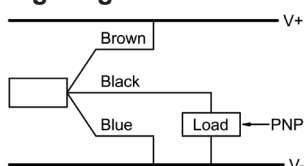

Wiring Diagram NPN NO/NC

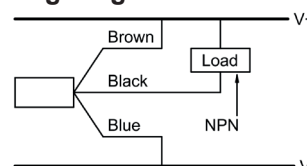

Special types and silicone free versions are available upon request

Design and technical details subject to change

Locon Sensor Systems, Inc.